



Guangzhou Best Electronic Technology co.,Ltd

www.entelechybattery.com

Address: 5/F, C District, No. 98, Road 9, Pacific Industrial Zone, Xintang Town, Zengcheng District, Guangzhou, China



BST-LRG BATTERY SPECIFICATION

Product type: LRG Battery

product model: BST-LRG-12.8V300Ah



Guangzhou Best Electronic Technology Co. ,Ltd

Amendment Records

Note: The company's electronic documents and printed documents with the red "Controlled Document" seal are controlled documents, and other printed documents are non-controlled documents.



1. Scope of application

This specification describes the technical index requirements of 12.8V300Ah lithium iron phosphate battery.

2. Model: 12.8V300Ah

2.1 The battery uses a cylindrical cell model of 32700 lithium iron phosphate 3.2V6Ah;

2.2 The entire battery pack is composed of 50PCS cells in parallel to form a battery string, and 4 strings of cells are connected in series to form a battery module, a total of 200PCS cells;

3. Reference standards and test requirements

3.1 YD/T2344.1-2011 Lithium iron phosphate battery pack for communication.

3.2 UN38.3 "Recommendation on the Transport of Dangerous Goods: Manual of Tests and Standards" Part III, Section 38.3

3.3 GB4208-2008/IEC60529:2001 Cover protection class (IP code)

3.4 GB/T 1804-2000 General tolerances Tolerances of linear and angular dimensions without tolerances

3.5 Standard test environment

Unless otherwise specified, all tests in this specification are carried out under the following environmental conditions:

Temperature: $(25 \pm 2)^\circ\text{C}$

Humidity: $(65 \pm 20)\%RH$

Standard charging current: 0.3C

Standard discharging current: 300 A

4. Technical Parameters

4.1 System parameters



Project		Specification	Remarks
1	Rated voltage	12.8V	
2	Nominal capacity	300Ah	After standard charging, 300A current discharge capacity: $\geq 285\text{Ah}$
3	Nominal voltage	12.8V	The median voltage of the standard discharge process after standard charging
4	Maximum continuous charging current	300A	
5	Maximum continuous discharge current	300A	
6	Maximum pulse discharge current	400A	Duration 5S
7	Cycle life	2000 cycles	$25^{\circ}\text{C} \pm 2^{\circ}\text{C}$; 1.0C charge, 1.0C discharge; 80%DOD
8	Upper charging voltage	$(14.6 \pm 0.05)\text{V}$	@ $(20-45)^{\circ}\text{C}$
9	Discharge termination voltage	10V	Determining discharge cutoff voltage of capacity, single series cutoff voltage 2.5V
10	Charge time	3.2h	Rated charging current: 0.3C
11	Charge-discharge efficiency	$\geq 97\%$	Volumetric efficiency
12	Cooling way	Natural cooling	
13	Water dust protection grade	IP54	
14	Operating Temperature	charging	$(0-60)^{\circ}\text{C}$
		discharge	$(-20-60)^{\circ}\text{C}$
15	Relative humidity	$(65 \pm 20)\%$	
16	Battery pack composition	50 parallel and 4 series	A total of 200PCS battery cells
17	Battery Pack Weight	$\leq 38\text{Kg}$	

Note: The company's electronic documents and printed documents with the red "Controlled Document" seal are controlled documents, and other printed documents are non-controlled documents.

4.2 BMS Parameters

4.2.1 BMSfunction introduction:

- Fully enclosed heat dissipation glue and heat dissipation design, heat can be discharged in time.
- Over voltage, less voltage, short circuit, overload protection and balance functions.
- Using an integrated solution, the performance of the protection board is more stable.
- Imported MOS tube, low internal resistance, high current and high precision.
- With RS485 communication function, it can realize real-time viewing of battery data.

4.2.2 Principle diagram

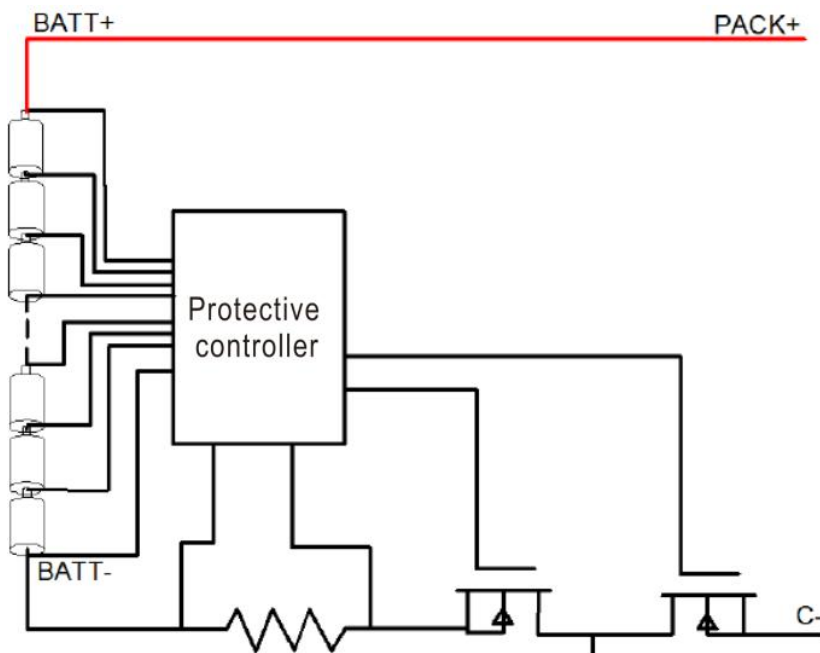

4.2.3BMSParameters

Output Voltage	Operating range	10V-14.6V
Operating current	Operating range	≤200A
Operating Temperature	Operating range	-20℃ ~ +70℃

Note: The company's electronic documents and printed documents with the red "Controlled Document" seal are controlled documents, and other printed documents are non-controlled documents.

Power Self-consumption	Power Self-consumption in working condition	≤100μA
internal resistance		≤20mΩ
Overcharge protection	Protection voltage	3.55±0.05V
	Recovery voltage	3.5±0.05V
	Over voltage protection delay	0.5~1.50S
Over discharge protection	Protection voltage	2.50±0.1V
	Recovery voltage	2.70±0.1V
	protection delay	0.50 ~ 1.50S
Over current protection	Discharge over current	400A
	Over current Recovery conditions	Disconnect load/charging
short circuit protection	protection delay	100-300us
	Recovery conditions	Disconnect load
Temperature protection	Over temperature protection temperature	NO
	Recovery temperature/time	NO
Charge balance	Charge balance start voltage	3.5±0.050V
	Balance current	25-35mA

4.3 Battery pack structure size

4.3.1 Battery outline drawing (520×269×219.3mm;tolerance class:GB/T1804-M)



12V300Ah Battery outside picture

(Picture only for you reference,result depends on production)

5. Battery performance

5.1 Cycle performance

Project		Standard	Test Conditions
1	25°C Cycle life	After 2000 cycles, the remaining capacity is $\geq 80\%$ of the rated capacity	In a 25°C environment, charge and discharge with 1.0C current 100% DOD

5.2 High and low temperature performance

Project		Standard	Test Conditions
1	-20°C low temperature discharge	Discharge capacity $\geq 70\%$ * rated capacity	After the battery pack is fully charged with 0.3C current, let it stand for 20h in an environment of $0^\circ\text{C} \pm 2^\circ\text{C}$, and discharge to the cut-off voltage at a constant current of 0.3C:
2	55°C High temperature discharge	Discharge capacity $\geq 100\%$ * rated capacity	After the battery pack is fully charged with 0.3C current, let it stand for 6h at $40^\circ\text{C} \pm 2^\circ\text{C}$ environment, discharge to cut-off voltage at 0.3C constant current

5.3 Storage performance

Project		Initial SOC	Standard	Condition	
1	Capacity retention rate	25 °C 28days	100%	90%	The percentage of the discharge capacity after storage to the capacity before storage, test condition: standard charge and discharge
		60°C 7day	100%		
2	Capacity recovery rate	25 °C 28days	100%	95%	After testing the remaining capacity after storage, charge and discharge as standard Power cycle 3 times, the highest capacity is the recovery capacity, the percentage of the recovery capacity and the capacity before storage is the recovery rate
		60°C 7day	100%		



6. Storage and transportation

6.1 According to the characteristics of the battery, the lithium iron phosphate battery pack should meet its storage environmental conditions during storage and transportation, so as to protect the battery performance to the utmost.

6.2 Appropriate protection should be provided during storage and transportation of lithium iron phosphate batteries; Maintain a SOC level of about 50%; ensure that no short circuit and liquid enter the lithium iron phosphate battery or soak in liquid (such as water, oil, etc.);

6.3 If not in use temporarily, the battery should be stored in a dry, clean and well-ventilated warehouse at 0°C ~ 45°C.

6.4 During the process of loading and unloading, the battery should be handled with care, and avoid dropping, rolling, and heavy pressure.

7. Safety rules

Misuse of lithium-ion rechargeable batteries may cause battery damage or personal injury. Before using the lithium-ion rechargeable battery, please read the following safety rules carefully

7.1 Battery precautions

7.1.1 Do not expose the battery to extreme heat or fire.

7.1.2 Do not short-circuit, overcharge or over-discharge the battery.

7.1.3 Do not subject the battery to excessive mechanical shock.

7.1.4 Do not immerse the battery in sea water or water, or make it damp.

7.1.5 Do not disassemble or repair the battery.

7.1.6 Do not put the battery and metal objects such as necklaces, coins or hairpins together.

7.1.7 Do not cause obvious damage or deformation of the battery.

7.1.8 Do not connect the battery directly to the socket.

7.1.9 Do not mix lithium-ion batteries.

7.1.10 Do not place the battery in direct sunlight.

7.1.11 Keep the battery away from children.

7.1.12 Do not puncture, beat or trample the battery.

7.2 Battery instructions

7.2.1 Charging

1) The battery charging temperature range is (0-60)°C.

2) Use a constant current and constant voltage lithium-ion battery charger.

3) Correctly connect the positive and negative poles of the battery, and reverse charging is strictly prohibited. If the positive and negative poles of the battery are reversed, there is a risk



of arcing and short circuit.

7.2.2 Discharge

- 1) The discharge temperature range of the battery is (-20-60)°C.
- 2) During the long period of non-use of the battery, the battery may be in a certain over-discharged state due to its self-discharge characteristics. In order to prevent the occurrence of over-discharge, the battery should be charged regularly to maintain its cell voltage between (3.3-3.5)V. Over-discharge will cause the loss of battery performance and function.