



Guangzhou Best Electronic Technology co.,Ltd

www.entelechybattery.com

Address: 5/F, C District, No. 98, Road 9, Pacific Industrial Zone, Xintang Town, Zengcheng District, Guangzhou, China



BST-LRG BATTERY SPECIFICATION

Product type: LRG Battery

product model: BST-LRG-12.8V80Ah



Guangzhou Best Electronic Technology Co., Ltd

Amendment Records

Note: The company's electronic documents and printed documents with the red "Controlled Document" seal are controlled documents, and other printed documents are non-controlled documents



1.Scope of application

This specification describes the technical index requirements of 12.8V80Ah lithium iron phosphate battery.

2. Model: 12.8V80Ah

2.1 The battery uses a cylindrical cell model of 32700 lithium iron phosphate 3.2V6Ah;

2.2 The entire battery pack is composed of 14PCS cells in parallel to form a battery string, and 4 strings of cells are connected in series to form a battery module, a total of 56PCS cells;

3. Reference standards and test requirements

3.1 YD/T2344.1-2011 communication lithium iron phosphate battery pack

3.2 UN38.3 "Recommendation on the Transport of Dangerous Goods: Manual of Tests and Standards" Part III, Section 38.3

3.3 GB4208-2008/IEC60529:2001 Enclosure protection class (IP code)

3.4 GB/T 1804-2000 General tolerances Tolerances of linear and angular dimensions without tolerances

3.5 Standard test environment

Temperature: (25±2)°C

Humidity: (65±20)%RH

Standard charging current: 0.3C

Standard discharging current: 80A

4. Technical Parameters

4.1 System parameters

	Project	Specification	Remarks
1	Rated voltage	12.8V	
2	Nominal capacity	80Ah	After charging, 0.3C discharging Capacity : ≥80Ah

Note: The company's electronic documents and printed documents with the red "Controlled Document" seal are controlled documents, and other printed documents are non-controlled documents



3	Nominal voltage	12.8V	During normal charging and discharging
4	Maximum continuous charging current	80A	1.0C
5	Maximum continuous discharging current	80A	1.0C; top current: 120A for 5s
6	Cycle lifespan	2000times	25°C±2°C; 1.0C for charging 1.0C for discharging 80%DOD;
7	Charging max voltage	(14.6±0.05)V	@(20-45)°C
8	Discharging termination voltage	8.8V	Determining discharge cutoff voltage of capacity, single series cutoff voltage 2.2V
9	Chaging time	About3h	Rated current0.3C
10	Charge-discharge efficiency	≥96%	Volumetric efficiency
11	Cooling way	Natural cooling	
12	Working temp	Charging	(0-60)°C
		Discharging	(-20-60)°C
13	Relative humidity	(65±20)%	
14	Relative humidity	(65±20)%	
15	Battery pack composition	14 parallel and 4 series	A total of 56PCS battery cells
16	Battery Pack Weight	≤11Kg	

4.2 BMS parameter

4.2.1 BMS function introduction

- Discharge over current protection function;
- Over voltage, under voltage, temperature and overload protection functions;
- Using an integrated solution, the performance of the protection board is more stable;
- Using contactor control, low internal resistance, high current, high precision;
- Using contactor control, low internal resistance, high current, high precision

Note: The company's electronic documents and printed documents with the red "Controlled Document" seal are controlled documents, and other printed documents are non-controlled documents

4.2.2 BMS parameter

Voltage	Charge voltage	14.6v
Work current	Working range	0-80A
Working tepe	Working range	-20°C ~ +60°C
Consumption	Working consumption	≤50μA
Internal		≤35mΩ
Over-charge protection	Protection voltage	3.75±0.05V
	Recovery conditions	3.55±0.05V
	Over-voltage protection delay	1000 ~ 3000mS
Over-discharge protection	Protection voltage	2.20±0.1V
	Recovery conditions	2.70±0.1V
	Over-voltage protection delay	1000~3000ms
Discharge over current protection	Protection current	120±5A
	Production delay	5S
Circuit protection	Production delay	200~600us
	Recover condition	Disconnect load or charge
Temp protection	charging protect temp	<0°C , >65°C
	discharging protect temp	<-20°C , >65°C
Charge balance	Charge balance voltage	3.5±0.05V
	Charge balance current	30±5mA

4.2.3 Schematic diagram of protection board

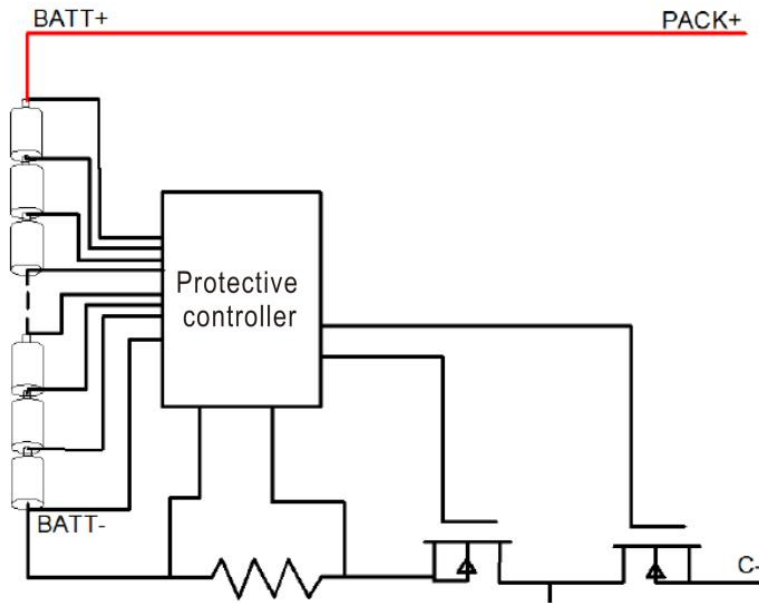

4.3 Battery pack structure size

4.3.1 Battery bag outside picture (size:307*168*208mm; tolerance class:GB/T1804-M)



12V80Ah Battery outside picture
(Picture only for you reference, result depends on production)

Note: The company's electronic documents and printed documents with the red "Controlled Document" seal are controlled documents, and other printed documents are non-controlled documents

5. Battery function

5.1 Cycle Function

Project		Standard	Test Condition
1	Cycle lifespan	After 2000 cycles, the remaining capacity is $\geq 80\%$ of the rated capacity	In a 25°C environment, charge and discharge with 0.3c Current 80% dod

5.2 High and low temperature performance

Project		Standard	Test Condition
1	-20°C low temperature discharge	Discharge capacity $\geq 70\%*$ rated capacity	After standard charging, in an environment of $-20^{\circ}\text{C} \pm 2^{\circ}\text{C}$, let it stand for 20h discharge to the cut-off voltage at a constant current of 0.3C
2	55°C High temperature discharge	Discharge capacity $\geq 95%*$ rated capacity	After standard charging, let stand for 5h at $55^{\circ}\text{C} \pm 2^{\circ}\text{C}$, discharge to cut-off voltage at 0.3C constant current

5.3 Storage function

Project		Initial SOC	Standard	Condition	
1	Capacity retention rate	25°C 1month	100%	90%	The percentage of the discharge capacity after storage to the capacity before storage, test condition: standard charge and discharge
		60°C 7day	100%	90%	
2	Capacity recovery rate	25°C 1month	100%	95%	After testing the remaining capacity after storage, charge and discharge as standard Power cycle 3 times, the highest capacity is the recovery capacity, the percentage of the recovery capacity and the capacity before storage is the recovery rate
		60°C 7day	100%	95%	

Note: The company's electronic documents and printed documents with the red "Controlled Document" seal are controlled documents, and other printed documents are non-controlled documents



6. Storage and transportation

- 6.1 According to the characteristics of the battery, the lithium iron phosphate battery pack should meet its storage environmental conditions during storage and transportation, so as to protect the battery performance to the utmost.
- 6.2 Appropriate protection should be provided during storage and transportation of lithium iron phosphate batteries; Maintain a SOC level of about 50%; ensure that no short circuit and liquid enter the lithium iron phosphate battery or soak in liquid (such as water, oil, etc.);
- 6.3 If not in use temporarily, the battery should be stored in a dry, clean and well-ventilated warehouse at 0°C ~ 45°C.
- 6.4 During the process of loading and unloading, the battery should be handled with care, and avoid dropping, rolling, and heavy pressure.

7. Safety rules

Misuse of lithium-ion rechargeable batteries may cause battery damage or personal injury. Before using the lithium-ion rechargeable battery, please read the following safety rules carefully

7.1 Battery precautions

- 7.1.1 Do not expose the battery to extreme heat or fire.
- 7.1.2 Do not short-circuit, overcharge or over-discharge the battery.
- 7.1.3 Do not subject the battery to excessive mechanical shock.
- 7.1.4 Do not immerse the battery in sea water or water, or make it damp.
- 7.1.5 Do not disassemble or repair the battery.
- 7.1.6 Do not put the battery and metal objects such as necklaces, coins or hairpins together.
- 7.1.7 Do not cause obvious damage or deformation of the battery.
- 7.1.8 Do not connect the battery directly to the socket.
- 7.1.9 Do not mix lithium-ion batteries.
- 7.1.10 Do not place the battery in direct sunlight.



7.1.11 Keep the battery away from children.

7.1.12 Do not puncture, beat or trample the battery.

7.2 Battery instructions

7.2.1 Charging

- 1) The battery charging temperature range is (0-60)°C.
- 2) Use a constant current and constant voltage lithium-ion battery charger.
- 3) Correctly connect the positive and negative poles of the battery, and reverse charging is strictly prohibited.
If the positive and negative poles of the battery are reversed, there is a risk of arcing and short circuit.

7.2.2 Discharge

- 1) The discharge temperature range of the battery is (-20-60)°C.
- 2) During the long period of non-use of the battery, the battery may be in a certain over-discharged state due to its self-discharge characteristics. In order to prevent the occurrence of over-discharge, the battery should be charged regularly to maintain its cell voltage between (3.3-3.5)V. Over-discharge will cause the loss of battery performance and function.